

# SMS Series

## PET Stretch-blow Molding Machine



# SMS600

## PET Stretch-blow Molding Machine



SMS600 is new-generation semi-auto stretch-blow molding machine to produce PET bottles from preforms. Only one worker is required to put preform onto machine's preform holder and the following preform heating, blowing and bottle discharging will finish automatically controlled by SIEMENS PLC system. With SMS600, you can produce PET bottle with volume up to 600ml. Using one-cavity blow mold, it can produce 600ml bottle with neck size between 15mm and 30mm up to 1500 bottle/hr.

- Neck range 15~30mm
- 1-cavity blow mold
- Pneumatic (SMC & LUCIFER)
- SIEMENS PLC control
- Infrared heating

SMS600 PET semi-auto stretch blow molding machine is made up of different systems. Thereinto, control system, pneumatic system, heating system and mechanical system are the main ones and will be introduced in sequence as follows.

## Control System

The control system is the heart of SMS600 series PET semi-auto stretch-blow molding machine, which is made up of PLC (Programmable Logic Controller) and heating control unit.

## Heating System

To ensure the preform get sufficient and correct heat is very important for following bottle blow. At the same time, how to steady the heating temperature and prevent the preform neck from overheating is another key point. On SMS600, you will find the ideal combination among heating, venting and cooling.

## Pneumatic System

Pneumatic system is the power source for SMS600's movement. According to different usage, the whole system has been divided into execute component, solenoid valve component and pneumatic auxiliary component

## Mechanical System

Like bone for human, mechanical system is very important for machine. On SMS600, you will find strong clamping unit, reliable seal and stretch device, smooth transferring chain-wheel and compact machine frame, all of which provide a heavy-duty capacity for SMS600 and ensures machine's long service life.

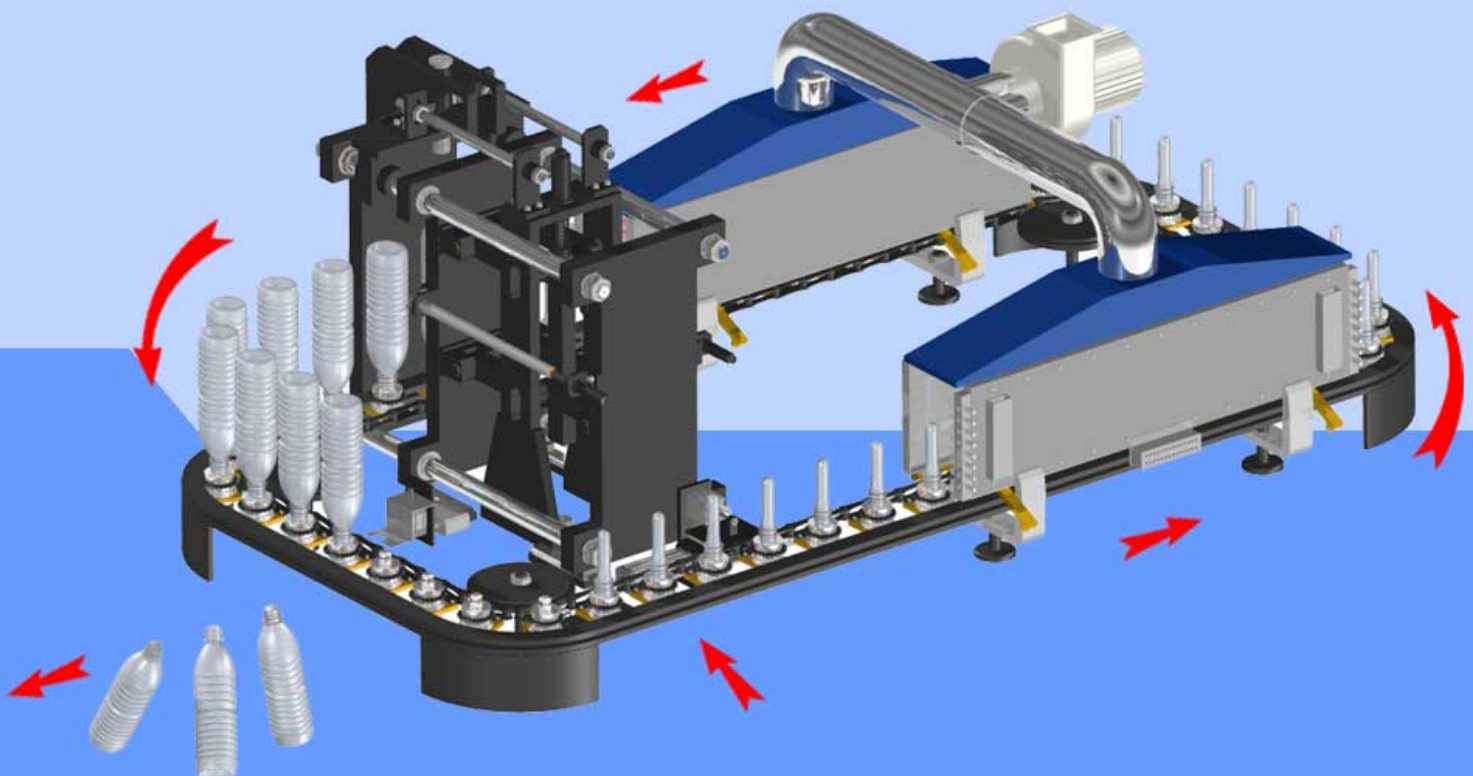



Preform Feeding Station



Preform Moving Unit



Bottle Discharge Unit

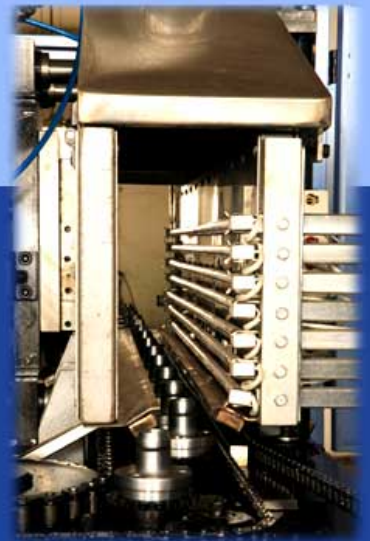

Preform Reheating Unit

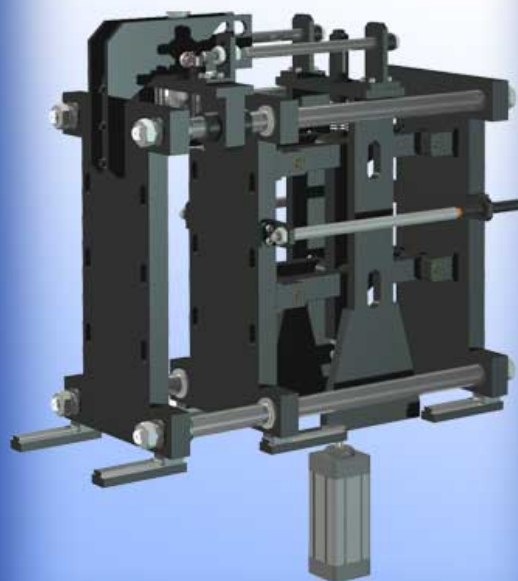

Clamping Unit



# Operating Description

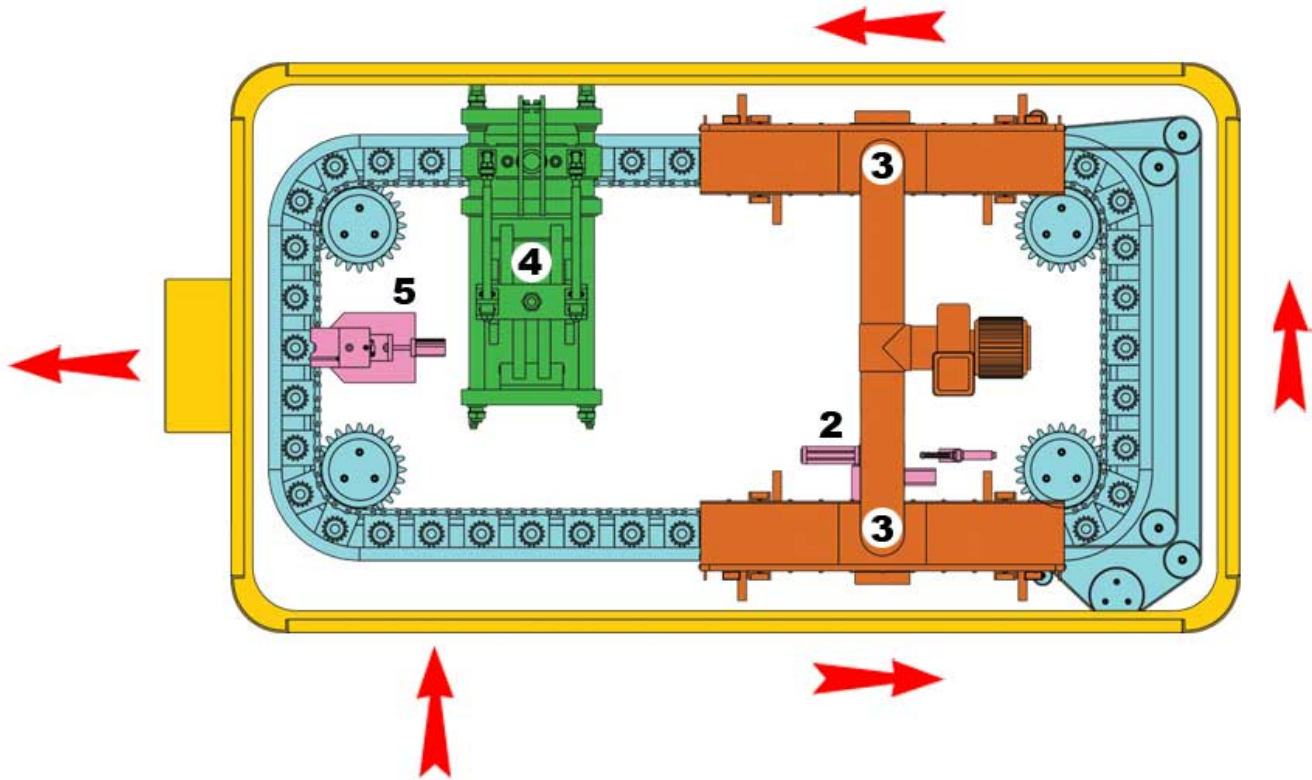

- (1) Input preform onto machine's preform holder
- (2) Transfer the preform along the moving rail
- (3) Heat the preform
- (4) Blow the heated preform into bottle
- (5) Discharge the bottle from the machine



# Design Galleries

Follows are some finish PET BOTTLE example that SMS600 can produce:



-  500ml
-  191.2mm
-  28mm
-  60.7X90.3mm
-  32g
-  1 Cavity



-  500ml
-  214.3mm
-  28mm PCO
-  65.4X65.4mm
-  28g
-  1 Cavity



**SMB-100710**

-  500ml
-  216.6mm
-  28mm PCO
-  64.5X64.5mm
-  24g
-  2 Cavities



-  600ml
-  220mm
-  28mm PCO
-  67.9X67.9mm
-  20g
-  1 Cavities

**Cavity Number:**

one cavity.

**Structure:**

It is made up of four parts: cavity body, base plate, bottom and neck.

**Material:**

The base plate, bottom and neck part will be made by steel. While, for cavity body, there are two kinds of material for selection - aluminum & steel. Light weight, fast heat conduction and complete rustproof are aluminum mold's prominent advantage. While, economical steel mold can be also considerable for investment-limit project.

**Dimension:**

The outside dimension is always the same, especially the thickness (170mm), and won't change along with bottle's shape and volume.

**Cooling:**

U-shape cooling groove has been made on the back of cavity body for ideal cooling. As for the mold bottom, water cooling, air cooling and blow doffing can be carried out at the same time to prevent bottle bottom from shrinking and being caught by the mold bottom.



Model		SMS600
Mold Cavity	No.	1
Max Body Diameter	mm	70
Max Body Height	mm	240
Neck Range	mm	15~30
Bottle Volume	L	up to 0.6
Max Nominal Output	b/h	1500
Heating Capacity	kw	12
Total Installed Power	kw	13
Mold Thickness	mm	170
Operating Pressure	bar	8~10
Blowing Pressure	bar	20~30
Temp. Control Point	pc	5
Dimension	mm	2000X1300X1400
Net Weight	kg	1200

NOTE: Specifications are subject to change without prior notice.

